

# AXS-400-S- Tier-8 Vault

Equivalent to a 13"x24"x18" Rectangular Vault

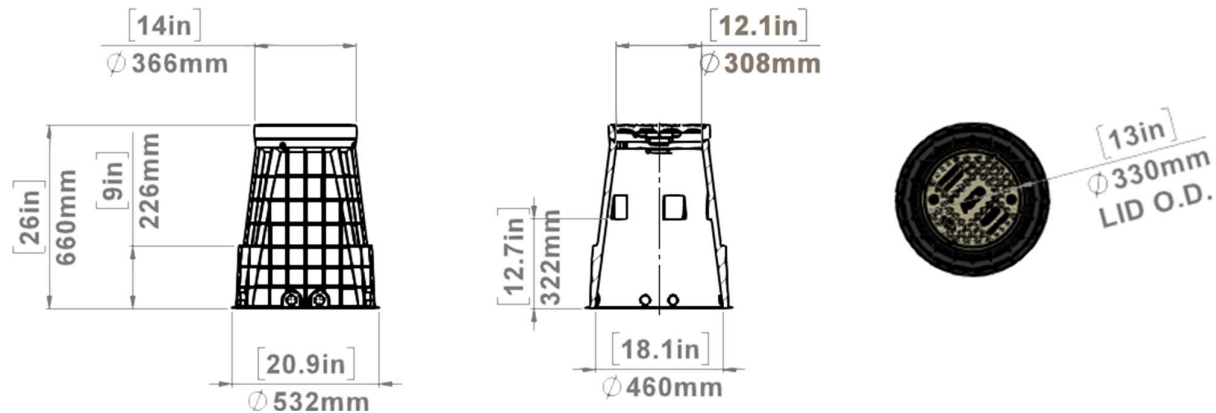

## Specs & Techs: AXS-400-S-Tier-8 Vault



### Description:

The AXS-400-S-Tier 8 is a purpose designed drop access and splice vault, that will cater to low to medium fiber counts. The AXS-400-S-Tier 8 is normally used to connect single family homes, MDU's, and backbone splicing.

### Features & Benefits:

- Manufactured in Single Shot Construction.
- Ideal for low to medium fiber count installations.
- Manufacture from lightweight, high strength composite materials.
- Small Surface footprint diameter of 14" [366mm].
- Tapered chamber design allowing for higher cable slack management.
- Optional knock-out conduit ports are located at the base of the chamber.
- A Hingeless slide-in lid, with bolt down locking technology.
- Branding: Fiber Optic, custom branding available upon request.



### Fire Retardancy & High / Low Temperature Performance:

- DMC will comply to SANS 713 grade F.
- Can be formulated to also comply to UL94 V-0.
- DMC is fire resistant, refer Telcordia GR-13 CORE Section 3.21.
- DMC can go to as low as -40°F [-40°C] in extreme conditions.
- Heat deflection temperature (HDT) under a load of 264psi [1.8 MPa] at 248°F - 356°F [120°C-180°C].
- Deflection temperature @ 1160psi [8MPa] at 176°F - 302°F [80°C-150°C].

### CONTACT & INFORMATION:

Tel: (920) 328-1020 Email: sales@raddnetwork.com Website: RaDDNetwork.com



**Technical Specifications:**

ITEM NO.	PART NUMBER	DESCRIPTION	QTY.
1.	AXS-400S-Tier 8	CHAMBER - PP - 7.5kg/ 16.5 pounds	1
2.	AXS-400-DMC-LID	Lid - DMC - 3.1kg / 6.8 pounds	1
3.	AXS-400-LID FRAME	Lid frame - DMC - 2.8kg/ 6.2 pounds	1
4.	FS031	S/Steel 7/16" x 37 Bolt	2
5.	7/16" Washer	7/16" Washer	2
6.	FS034	S/Steel Lifting Eye (M10)	1
7.	M10NYLOCK	M10 Nylock	1
8.	FS036	S/Steel M10 Washer	1
9.	M6 BOLT	M6 Bolt	4
10.	M6 WASHER	M6 Washer	4
11.	M6 NUT	M6 Nut	4

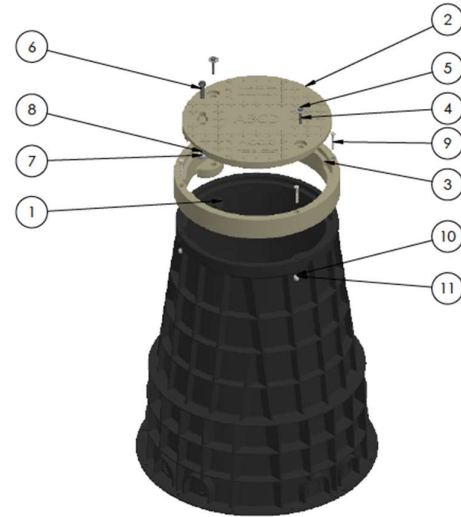

**Weight & Load Case:**

Weight lbs/KG	27.8 lbs [12.6 kg]
Load Class:	
EN 124	A15 - 15kN
ANSI	Tier 8

**Shipping:**

Loading Qty's (Product Code)	QTY/Pallet	12m (40') Container	53' Semi Trailer
AXS-400-S-Tier-8	64	704	TBC <span style="background-color: yellow; border: 1px solid black; display: inline-block; width: 15px; height: 15px;"></span>

**Installation Instructions:**

As with all structures, proper installation and backfilling are critical. Improper installation practices may lead to failure. All practices should comply with OSHA, State, Federal regulations.

**STEP 1 - BEDDING**

Vault should be placed on a minimum of 6" of properly compacted, free draining material. ¾" washed stone or sand is recommended.

**STEP 2 - BACKFILLING**

Backfilling around vault should be done uniformly around vault in 3"-4" lifts. Material should be properly compacted to meet project specifications; excessive mechanical compaction should be avoided.